

ECOPURE®

Water Solved.®

Model EPAWCS

How to install, operate
and maintain your
Salt-Free Whole Home
Water Conditioner

Do not return unit to store

If you have any questions or concerns when installing, operating or maintaining your water filtration system, call our toll free number:

1-800-693-1138

or visit **www.ecopure.com**

When you call, please be prepared to provide the model number and date code of your system, found on the rating decal.

System tested and certified by NSF International against NSF/ANSI Standard 42 for particulate class III reduction and chlorine taste and odor reduction. System tested and certified to CSA B483.1 and NSF/ANSI/CAN 372.

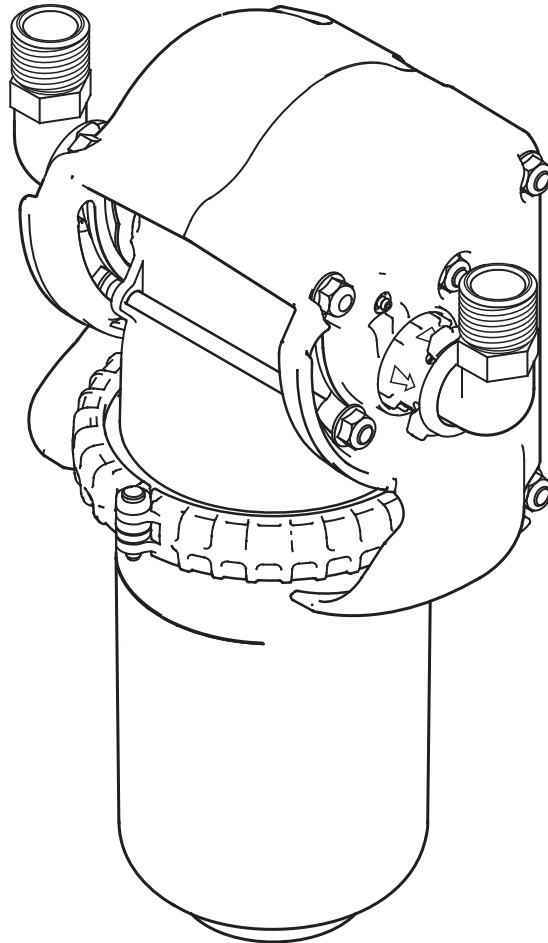

Installation and Operation Manual

Manufactured and warranted by
Water Channel Partners
2805 Dodd Road, Suite 300
Eagan, MN 55121

7371038 (Rev. G 12/1/24)

TABLE OF CONTENTS

	<u>Page</u>
Dimensions	2
Specifications & Performance Claims	3
Inspect Shipment	4
Before You Start	4
Planning the Installation	5
Typical Installation Illustrations	6
Installation Instructions	7
Always Install the Filter Upright	7
Mounting Bracket	7
Plumbing Codes	7
Connect the Vent Tube	7
Grounding Information	7
Filter Cartridges	8-9
Filter Cartridge Life	8
Filter Cartridge Replacement	8-9
Troubleshooting the System	9
Warranty	10
Exploded View & Parts List	11

Dimensions

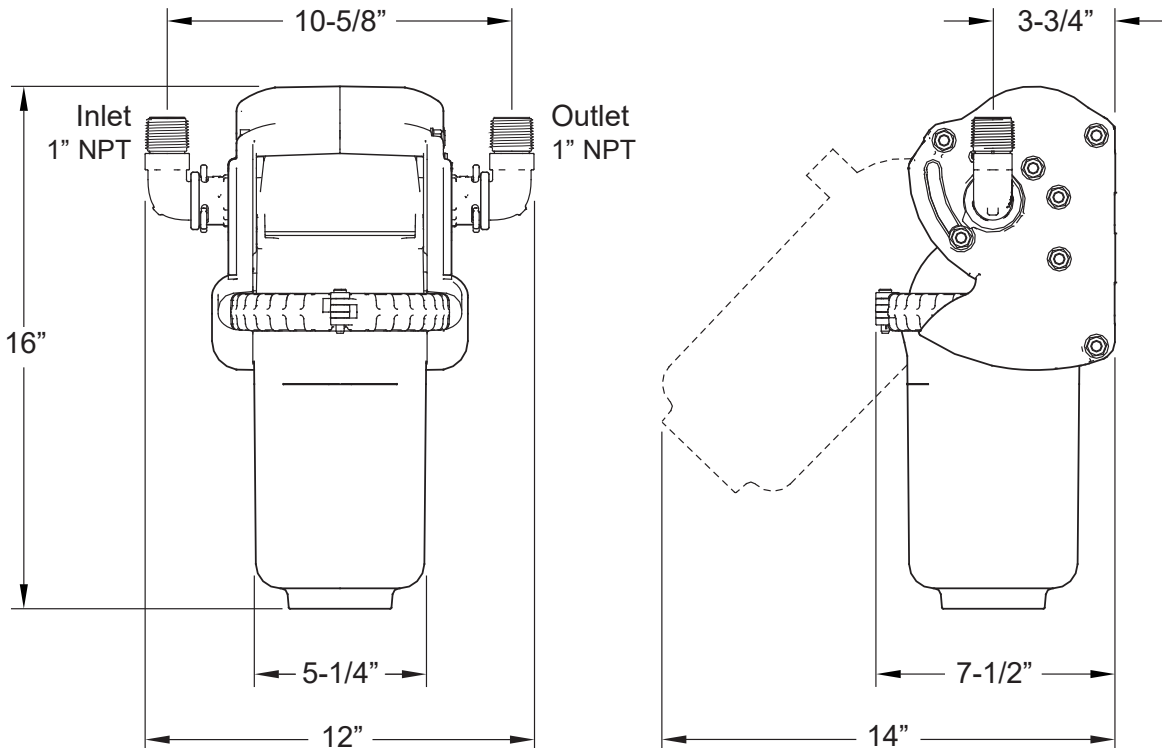

FIG. 1

Specifications & Performance Claims

This system has been tested according to NSF/ANSI Standard 42 for the substances listed below. The concentration of the indicated substance in water entering the system was reduced to a concentration less than or equal to the permissible limit for water leaving the

system, as specified in NSF/ANSI 42. The testing was performed using spiked tap water at a flow rate of 4 GPM (15.2 L/min.), pH of 7.5 ± 0.5, pressure of 60 PSIG, and temperature of 68 ± 5°F.

SPECIFICATIONS	
	Model EPAWCS
Rated Service Flow Rate @ 60 psi (414 kPa)	4.0 gpm (15.2 L/min.)
Pressure Drop @ 30 psi (207 kPa)	2 psig (13.8 kPa)
Water Pressure Limits (minimum / maximum)	30 - 100 psi (207 - 689 kPa)
Water Temperature Limits (minimum / maximum)	40 - 100 °F (5 - 38 °C)
Capacity	10,000 gallons (37,850 liters)

IMPORTANT NOTICE: Read this performance data and compare the capabilities of this unit with your actual water treatment needs. It is recommended that, before purchasing a water treatment unit, you have your water supply tested to determine your actual water treatment needs. This filter system is designed to be used for the reduction of the performance claims listed below. Do not use where water is microbiologically unsafe or of unknown quality, without adequate disinfection before or after the system. While testing was performed under standard laboratory conditions, actual performance of the system may vary based on

local water conditions. Some or all of the contaminants reduced by this unit may not be in your water supply. See elsewhere in this manual for further instructions on system installation, operating procedures, filter cartridge replacement, and warranty. The maintenance instructions must be followed for the product to perform as indicated below.

Filter cartridges should be replaced every six months. Pricing will vary. Current pricing on replacement filter cartridge EPAWCF is approximately \$30.00 to \$60.00 per filter element. Call 1-800-693-1138.

PERFORMANCE CLAIMS						
Substance	Required Influent Level	NSF Min. % Reduction Requirement ^③	Average Influent Level	Avg. / Max. Effluent Level	Avg. / Min. Percent Removal	EPA Max. Contaminant Level ^⑤
Particulates, Class III (5 to <15 micron) ^①	10,000 mg/L ^②	85%	180,000 particles/mL ^④	26 / 45 particles/mL ^④	99.9% / 99.9%	None
Chlorine Taste and Odor	2.0 mg/L ^②	50%	1.9 mg/L ^②	0.10 / 0.19 mg/L ^②	94.9% / 90%	None

① Micron is equivalent to micrometer (µm).

② Milligrams per liter, which is equivalent to parts per million (PPM).

③ Acceptance level for this substance is based on percent reduction, rather than maximum effluent concentration.

④ Particles per milliliter.

⑤ Environmental Protection Agency maximum contaminant level as required under the Safe Drinking Water Act.

Inspect Shipment

Packing List

The parts required to assemble and install the water filtration system are included with the unit.

Thoroughly check the water filtration system for possible shipping damage and parts loss. Also inspect and note any damage to the shipping carton.

Remove and discard (or recycle) all packing materials. To avoid loss of small parts, we suggest you keep the small parts in the parts bag until you are ready to use them.

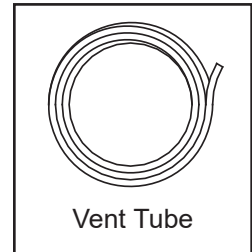
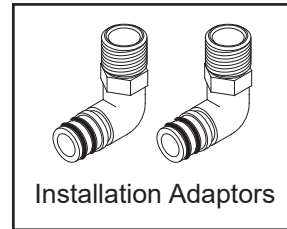
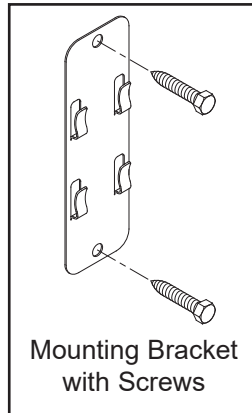

FIG. 2

Before You Start

Your safety and the safety of others are very important.

We have provided many safety messages in this manual and on your appliance. Always read and obey all safety messages.



This is the safety alert symbol.

This symbol alerts you to potential hazards that can kill or hurt you and others.

All safety messages will follow the safety alert symbol and either the word "DANGER" or "WARNING"

These words mean:

! DANGER

You can be killed or seriously injured if you don't immediately follow instructions.

! WARNING

You can be killed or seriously injured if you don't follow instructions.

All safety messages will tell you what the potential hazard is, tell you how to reduce the chance of injury, and tell you what can happen if the instructions are not followed.

- ▼ Read all instructions before installing and using your Salt-Free Whole Home Water Filtration System. Follow all steps exactly to correctly install. Reading this manual will also help you to get all the benefits from the filtration system.
- ▼ All plumbing must be completed in accordance with national, state and local plumbing codes. Local code information can be obtained at your local public works department. In Massachusetts, plumbing code 248 CMR 3.00 and 10.00 shall be adhered to. Consult with your licensed plumber.
- ▼ Do not use with water that is microbiologically unsafe or of unknown quality without adequate disinfection before or after the system.
- ▼ The Salt-Free Whole Home Water Filtration System works on water pressures of 30 psi (minimum) to 100 psi (maximum). If your house water pressure is over the maximum, install a pressure reducing valve in the water supply pipe to the filtration system.
- ▼ To condition all water in the home, install the filtration system close to the water supply inlet, and before all other plumbing connections, except outside water pipes.
- ▼ Do not install the filtration system outside, or in extreme hot or cold temperatures. Temperature of the water supply to the filtration system must be between 40°F and 100°F. Do not install on hot water.
- ▼ Avoid installing in direct sunlight. Excessive sun heat may cause distortion or other damage to non-metallic parts.

Planning the Installation

INSTALLATION LOCATION

To filter all household water, install the Salt-Free Whole Home Water Filtration System on the household's main incoming water pipe.

Install the filter between the home's incoming water supply and the water heater (See Figure 3).

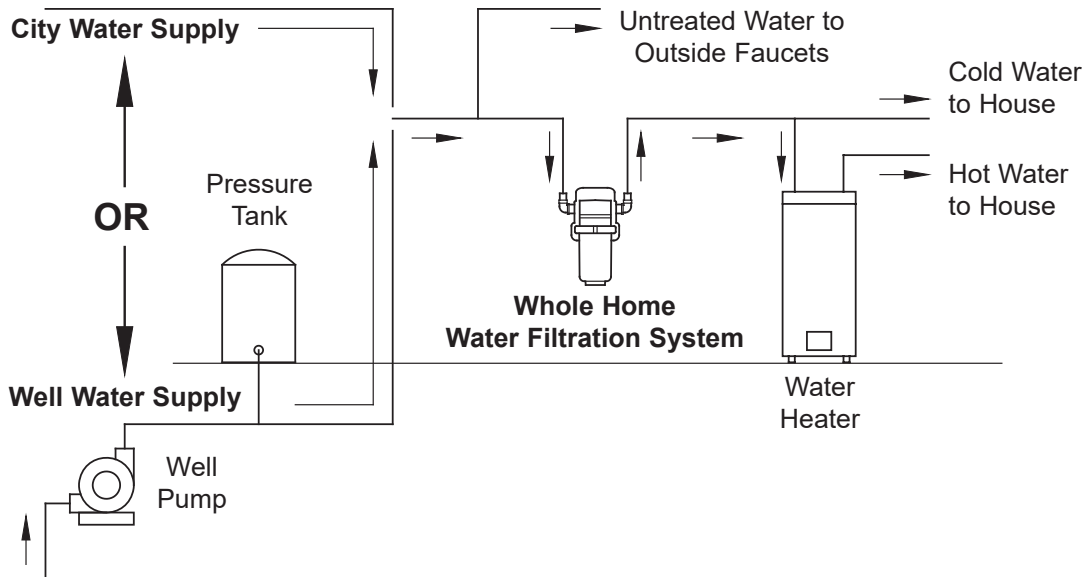



FIG. 3

⚠ WARNING

Electrical Shock Hazard
Prior to installation on metallic plumbing, securely install two grounding clamps and a #4 copper wire per installation instructions.
Failure to follow these instructions can result in death or electrical shock.

In some cases it may be necessary for plumbing to cross over to ensure the correct flow direction through the filter (See Figure 4).

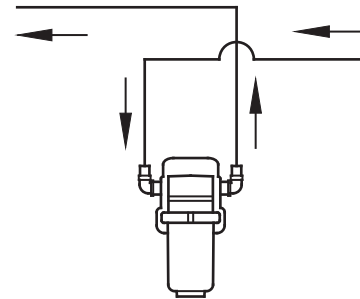

FIG. 4

Typical Installation Illustrations

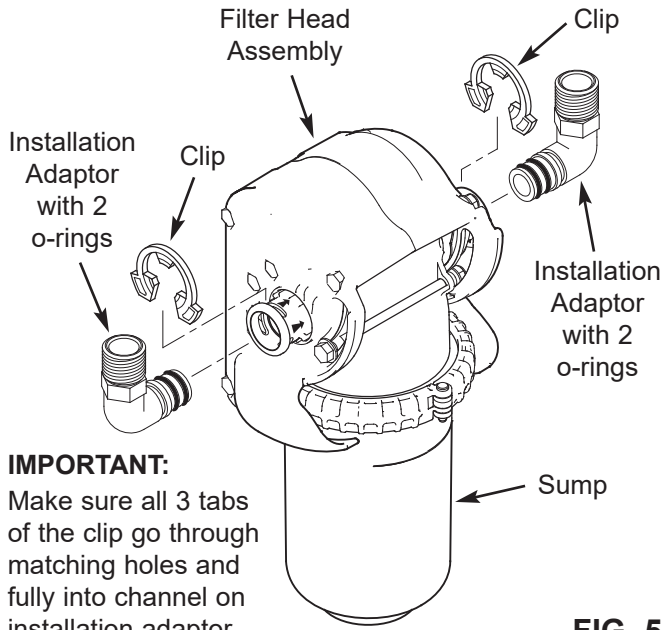

FIG. 5

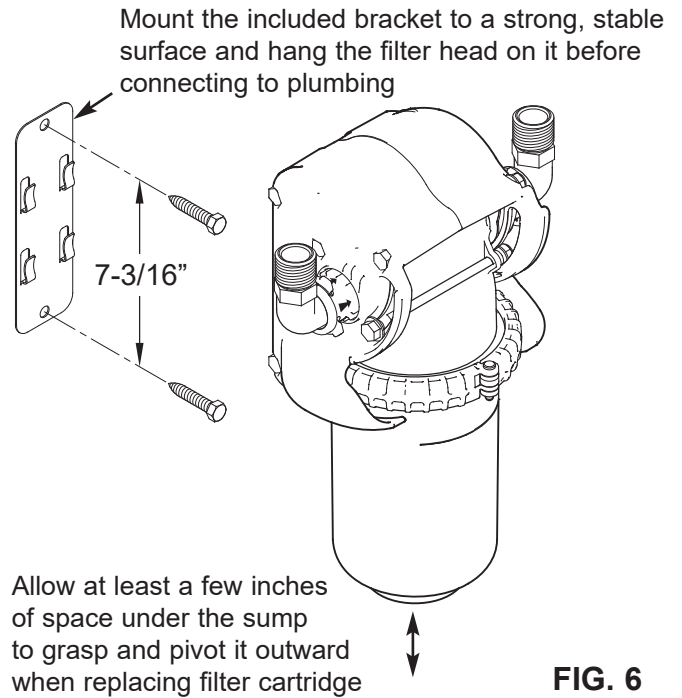

FIG. 6

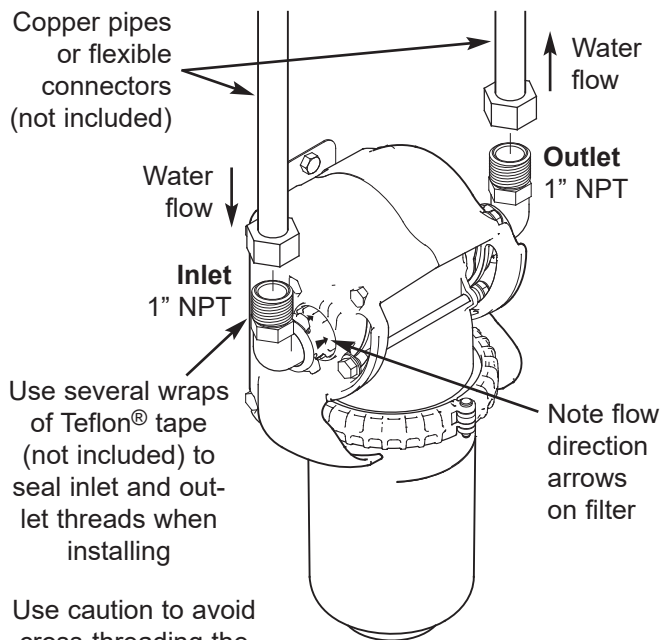

FIG. 7

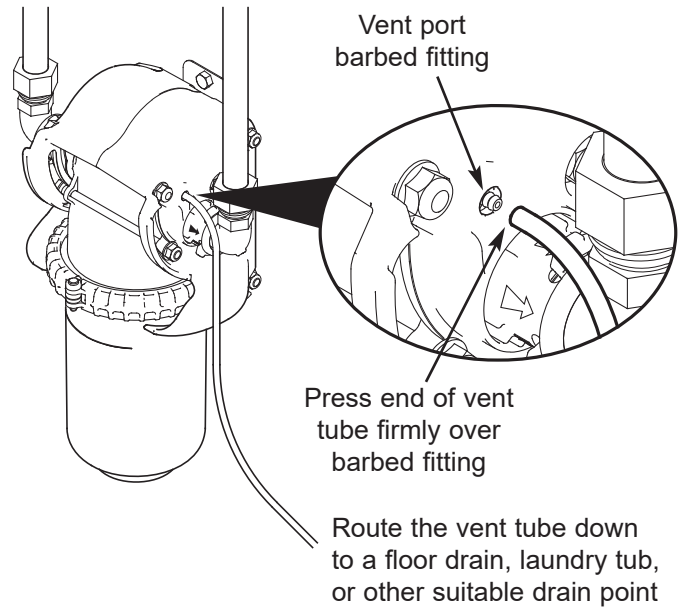

FIG. 8

IMPORTANT: Do not solder metal plumbing while attached to plastic installation adaptors. Soldering heat will damage the adaptors.

© Teflon is a registered trademark of E.I. Du Pont de Nemours and Company.

Questions? Call Toll Free 1-800-693-1138 or visit www.ecopure.com

When you call, please be prepared to provide the model number and date code, found on the rating decal.

Installation Instructions

PLUMBING CODES

All plumbing must be completed in accordance with national, state and local plumbing codes. Local code information can be obtained at your local public works department.

ALWAYS INSTALL THE FILTER UPRIGHT

To operate properly, the Salt-Free Whole Home Water Filtration System must be installed in a vertical orientation. The filtration system must also be installed with the water flow following the arrows on the filter's inlet and outlet. This corresponds to a left-to-right flow, when looking at the front of the filter head assembly (See Fig. 7). Leave a few inches of space under the filter sump to allow it to be grasped, pivoted up and removed when changing filter cartridges, as shown in the "Filter Cartridge Replacement" section.

MOUNTING BRACKET

A metal bracket is included with the Salt-Free Whole Home Water Filtration System to support the assembled filter and plumbing when necessary. The bracket should be installed before the filter is connected to the plumbing.

The bracket may be mounted to a wall or wall framing member with two screws (included), as shown in Figure 6. These screws, or other (not included) fasteners, if used, must be mounted into a stable surface, strong enough to support the weight of the filter, plumbed and full of water - about 15 pounds.

The back of the filter head housing clips onto the bracket. When mounted, the filter should be aligned with the inlet and outlet plumbing, and not cause rigid pipes to distort.

CONNECT THE VENT TUBE

Each time you replace a filter cartridge, the filter will be placed into the bypass position by pivoting it outward (shown in the "Filter Cartridge Replacement" section). Whenever this is done, water pressure inside the sump is relieved, and about 4 ounces of water will be expelled through the vent port. Always install the included vent tube on this barbed fitting to carry the water to a floor drain, laundry tub or other suitable drain point. See Figure 8.

NOTE: This vent tube works by gravity. Do not elevate it above the vent port. Route it downward to the drain point with no humps, dips or loops.

In the state of Massachusetts: The Commonwealth of Massachusetts plumbing code 248-CMR shall be adhered to. A licensed plumber shall be used for this installation.

⚠ WARNING



Electrical Shock Hazard

Prior to installation on metallic plumbing, securely install two grounding clamps and a #4 copper wire per installation instructions. Failure to follow these instructions can result in death or electrical shock.

GROUNDING INFORMATION (for Installations on Metal Pipe)

The house main incoming water pipe is often used to ground electrical outlets in the home. Grounding protects you from electrical shock. Installing the water filtration system may break this ground. Before beginning installation, purchase and securely install two grounding clamps and a #4 copper wire across the location where the filter will be, tightly clamping it at both ends, as shown below.

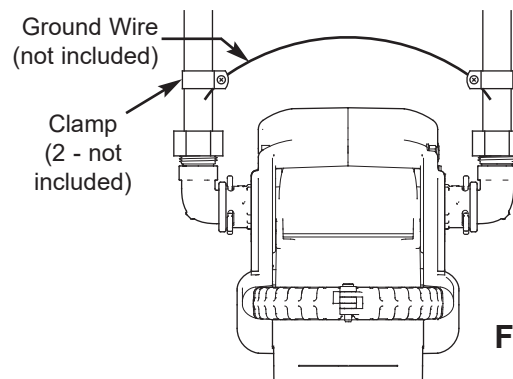

Properly discard (or recycle) all packing materials.

Filter Cartridges

FILTER CARTRIDGE LIFE

It is recommended to **replace filter cartridge every six months** of use. There are several variables that determine how long a cartridge will last.

These include:

1. How much water you use, and
2. How much sediment, taste and/or odor, or other unwanted substance, is in the water.

You will know it is time to replace the cartridge when you first notice the return of the unwanted sediment, taste and/or odor in your water, or when the flow diminishes or stops.

FILTER CARTRIDGE REPLACEMENT

NOTE: It is not necessary to shut off the water supply when replacing the filter cartridge.

1. Grasp the lower part of the sump and pull it firmly and slowly toward you, pivoting upward until it stops in the bypass/filter change position (See Fig. 10). You may notice a hissing sound, as a small amount of water (approximately 4 ounces) is expelled into the vent tube to relieve pressure in the sump.

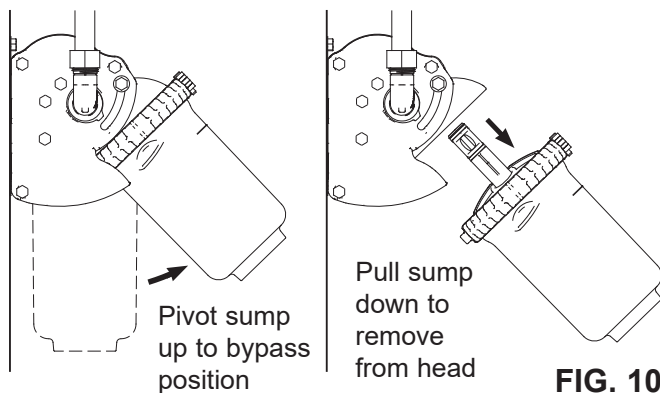

FIG. 10

2. Pull the sump downward out of the head.

NOTE: To avoid unintended water flow from the filter head, do not pivot filter head down to the service position without the sump and replacement filter cartridge in place, as shown in Figure 16.

3. It is recommended to take the sump assembly to a sink or level waterproof surface before opening it.
4. Unsnap the lid clamp by pulling its latches in opposite directions, as shown in Fig. 11. Do not pry or use tools, as this may damage the assembly.

Register for reminders to change filters
at www.ecopure.com

Replacement element EPAWCF, for EcoPure Salt-Free Whole Home Water Filtration System model EPAWCS.

Pull latches in opposite directions to unsnap

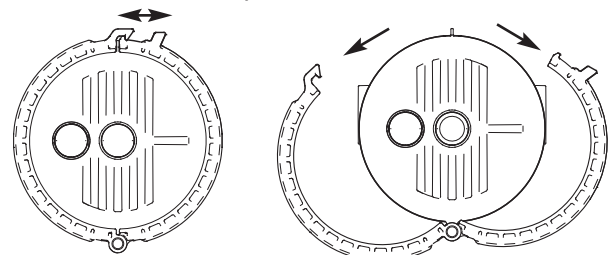

Top view of lid

FIG. 11

5. Swing the clamp halves open and lift the lid assembly up off the filter cartridge and sump.

NOTE: Do not remove the pin holding the clamp halves to the lid.

6. Remove the used filter cartridge from the sump. If you have difficulty removing cartridge from sump, insert a screwdriver into the slot shown in Figure 12 and pry up. Dispose of used cartridge properly.

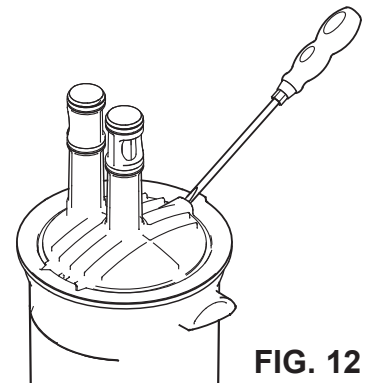

FIG. 12

NOTE: The water remaining in the used filter cartridge may contain a small amount of filter media "beads". If pouring this water out, be sure to dispose of the media in a manner which will avoid plugging the drain.

continued on next page

Filter Cartridges

NOTE: Check the sump to be sure it is dry and free of debris.

- Take the new filter cartridge out of its packaging and remove the protective caps from the ports (See Fig. 13).

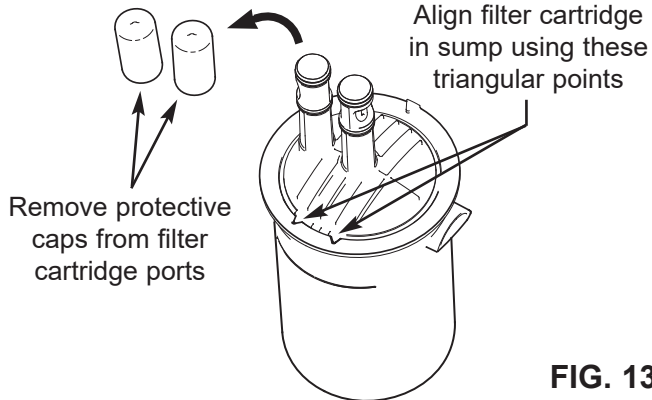

FIG. 13

- Filter cartridges can only be installed in one orientation, and are “keyed” to assure proper fit. Insert the new filter cartridge into the sump, and turn it until the triangular points on its top edge align with, and drop into the corresponding detents in the sump (see Fig. 13).

- Slide the lid assembly down over the replacement cartridge’s ports until it sits flat on top of the sump, then lock the clamp onto the sump by pinching together the latches, as shown in Fig. 15, until they snap. The clamp will not snap unless the cartridge and sump are properly seated and aligned.

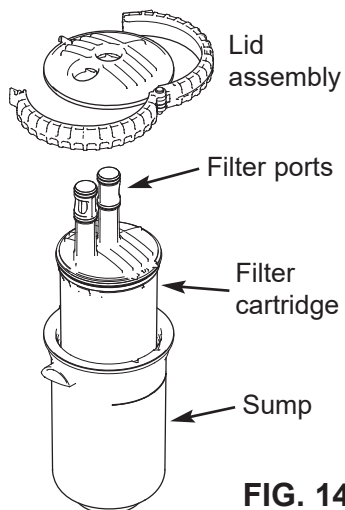

FIG. 14

- Insert the sump assembly into the head by guiding the filter ports into the corresponding receptacles in the head and pushing the sump upward until it stops (See Fig. 16).

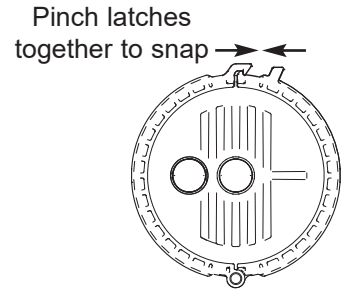

FIG. 15

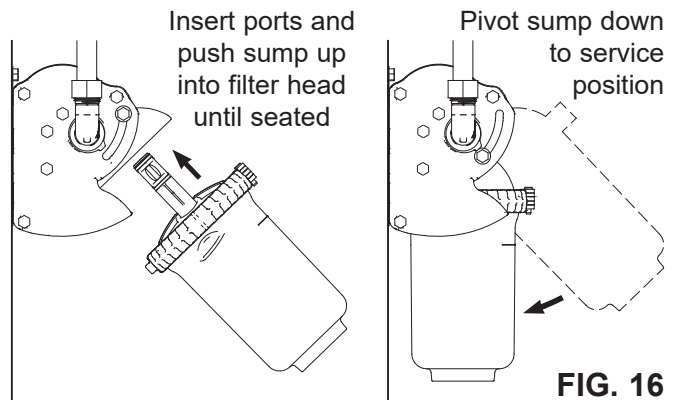

FIG. 16

- Pivot the sump all the way down to the service position.
- Some types of filter cartridges contain activated carbon, a black powder. Open a faucet downstream from the filter to purge air and fine carbon particles from the cartridge. Flush for at least 5 minutes.

Questions? Call Toll Free 1-800-693-1138 or visit www.ecopure.com

When you call, please be prepared to provide the model number and date code, found on the rating decal.

Troubleshooting the System

Problem: Replacement Filter cartridge does not fit in filter sump.	
Cause: Filter cartridge not properly oriented.	Correction: Reorient filter cartridge per Figure 13.
Problem: Lid does not fit on filter.	
Cause: Filter cartridge not properly oriented.	Correction: Reorient filter cartridge per Figure 13.
Problem: Lid clamp cannot be latched.	
Cause: Filter cartridge not properly oriented.	Correction: Reorient filter cartridge per Figure 13.
Problem: Water leaks from adaptor at threads.	
Cause: Inadequate seal on threads.	Correction: Reinstall adaptor with adequate Teflon [®] tape or plastic compatible pipe sealant on threads.
Problem: Water leaks from adaptor at o-rings.	
Cause: O-ring damaged.	Correction: Inspect and replace o-ring if damaged.
Problem: Water drips from outlet side of filter head, near vent tube.	
Cause: Water flowing back through vent hose.	Correction: Make sure vent hose is not elevated above filter head.

WARRANTY

TWO YEAR LIMITED WARRANTY ON SALT-FREE WHOLE HOME WATER FILTRATION SYSTEM MODEL EPAWCS (not including filter cartridges)

Warrantor: Water Channel Partners, 2805 Dodd Road, Suite 300, Eagan, MN 55121

Warrantor guarantees, to the original purchaser when the product is purchased from an authorized dealer, and when installed and maintained in accordance with the instructions, that the Salt-Free Whole Home Water Filtration System (EPAWCS) will be free from defects in materials and workmanship and will perform in accordance with its written specifications for a period of two (2) years from the date the product is delivered.

If, within the first two years, a part proves, after inspection, to be defective, Warrantor will, at its sole option, either replace or repair the part without charge except normal shipping and installation charges. If a repair or replacement part is unavailable, Warrantor may refund the original purchase price. Labor to maintain the equipment is not part of the warranty. Filter cartridges, which are expendable, are not covered by the warranty.

If you have questions regarding a warranted product, need assistance with installation or troubleshooting, wish to order a part or report a warranty issue, we are just a phone call away. SIMPLY DIAL 1-800-693-1138 for assistance.

General Provisions

The above warranties are effective provided the Salt-Free Whole Home Water Filtration System is operated at water pressures not exceeding 100 psi (7.0 kg/cm²), and at water temperatures not exceeding 100°F (38°C); provided further that the Salt-Free Whole Home Water Filtration System is not subject to abuse, misuse, alteration, neglect, freezing, accident or negligence; and provided further that the Salt-Free Whole Home Water Filtration System is not damaged as the result of any force of nature such as, but not limited to, flood, hurricane, tornado or earthquake.

The limited warranty does not cover damage due to: (a) transportation, (b) storage, (c) improper use, (d) failure to follow the product instructions or to perform any preventive maintenance, (e) modifications, (f) unauthorized repair, (g) normal wear and tear, or (h) external causes such as accidents, abuse, or other actions or events beyond Warrantor's reasonable control. Use of aftermarket, used, or non-manufacturer provided parts will void all warranties. Warranty does not cover failures due to improper product installation. Warrantor is excused if failure to perform its warranty obligations is the result of strikes, government regulation, materials shortages, or other circumstances beyond its control.

THERE ARE NO WARRANTIES ON THE SALT-FREE WHOLE HOME WATER FILTRATION SYSTEM BEYOND THOSE SPECIFICALLY DESCRIBED ABOVE. ALL IMPLIED WARRANTIES, INCLUDING ANY IMPLIED WARRANTY OF MERCHANTABILITY OR OF FITNESS FOR A PARTICULAR PURPOSE, ARE DISCLAIMED TO THE EXTENT THEY MIGHT EXTEND BEYOND THE ABOVE PERIODS. THE SOLE OBLIGATION OF WARRANTOR UNDER THESE WARRANTIES IS TO REPLACE OR REPAIR THE COMPONENT OR PART WHICH PROVES TO BE DEFECTIVE WITHIN THE SPECIFIED TIME PERIOD, AND WARRANTOR IS NOT LIABLE FOR CONSEQUENTIAL OR INCIDENTAL DAMAGES. NO DEALER, AGENT, REPRESENTATIVE, OR OTHER PERSON IS AUTHORIZED TO EXTEND OR EXPAND THE WARRANTIES EXPRESSLY DESCRIBED ABOVE.

Some states do not allow the exclusion or limitation of incidental or consequential damages, so the above limitation or exclusion may not apply to you. This warranty gives you specific legal rights, and you may have other rights which vary from state to state. This warranty applies to consumer-owned installations only.

Parts List

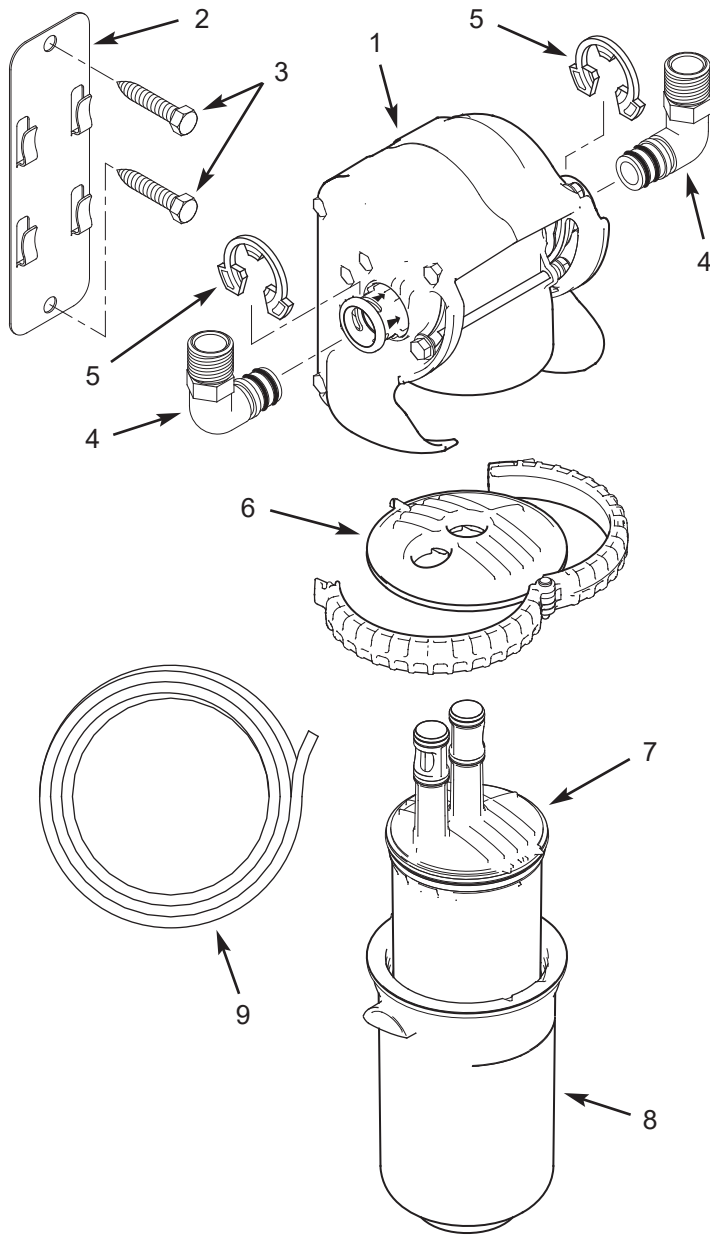

Key No.	Part No.	Description
1	1042-32-HF	Head Assembly
-	1042-32-HE	Mounting Kit (includes Key Nos. 2 & 3)
2	↑	Mounting Bracket
3	↑	Mounting Screw (2)
-	1042-32-HB	Adaptor Kit (includes Key Nos. 4 & 5)
4	↑	Installation Adaptor Elbow, 1" NPT, including o-rings (2)
5	↑	Clip (2)
6	1042-32-HD	Lid & Clamp Assembly
7	EPAWCF	Repl. Filter Cartridge *
8	1042-32-HC	Sump
9	1042-32-47	Vent Tube, 6 ft. long

* Please purchase replacement cartridges from the retailer where you bought your water filtration system.

To order repair parts, call toll free 1-800-693-1138.

Manufactured and warranted by
 Water Channel Partners
 2805 Dodd Road, Suite 300
 Eagan, MN 55121